

C-LAB Technology Media Platform FUTURE VISION LAB 2024

Guideline for Applicants

I. Purpose

In 2020, the Taiwan Contemporary Culture Lab (C-LAB) established the Technology Media Platform which emphasizes on innovative media experimentation and social connections. Its purpose is to construct a cultural and technological experimental platform based on cross-disciplinary collaboration, co-creation, and cooperation to facilitate the integration of Taiwan's cultural and technological resources while bringing together the cultural and technological sectors for co-creation. One of the labs of the platform features future visions, exploring the visual limits of technology media as its goal of experimentation. Building upon image algorithms and creation, as well as integration of hardware and software, the project outlines a cross-disciplinary vision for the enhancement of future visual effects.

For this edition of FUTURE VISION LAB, based on the concept of digital architecture, the Technology Media Platform re-develop an outdoor space DOME, which measures 15 meters. To create an immersive projection in the experiential dome space, multiple complicated techniques are involved, such as image warping, edge blending, mapping, play control, and image preprocessing, all of which are necessary for a fully immersive experience for the audience. From the floor, and the surrounding wall, to its zenith, the DOME's interior is a streamlined spherical space, which renders the viewing of video works similar to that of naked-eye virtual reality. Meanwhile, the DOME is also an immersive site, which fits the innovative concept of "future vision."

With a comprehensive hardware upgrade, "FUTURE VISION LAB 2024" will be launched from November to December 2024. The project will include a selection of works via an open call for individuals or groups who focus on immersive audiovisual creations and cross-disciplinary exhibitions/performances.



II. Project Description

1. Content

The open call invites artists and collectives to create works for the DOME. The creative content and genres include but not limited to audiovisual art, experimental images, experimental animation, performing arts, AR, VR, AI, and algorithmic presentations. Forms of exhibitions/performances include but not limited to pre-recorded programs, live performances, dynamic exhibitions, and other experimental forms. The duration of the work shall not be less than **12 minutes**. The number of selected projects can be up to **6 groups**.

For programs of selected projects from the past editions, see the following links:

- [FUTURE VISION LAB 2023](https://clab.org.tw/en/project/future-vision-lab-2023/) (https://clab.org.tw/en/project/future-vision-lab-2023/)
- [FUTURE VISION LAB 2022](https://clab.org.tw/en/project/future-vision-lab-2022/) (https://clab.org.tw/en/project/future-vision-lab-2022/)
- [FUTURE VISION LAB 2021](https://clab.org.tw/en/project/future-vision-lab-2021/) (https://clab.org.tw/en/project/future-vision-lab-2021/)
- [FUTURE VISION LAB](https://clab.org.tw/en/project/future-vision-lab/) (https://clab.org.tw/en/project/future-vision-lab/)

For results of realized projects, see related posts on the FB fan page of the Technology Media Platform at [C-LAB – Technology Media Platform](#).

2. Supports

For the selected projects and experimental groups, C-LAB will provide the exhibition/performance space, basic equipment and related technical assistance, marketing campaign and exposure for promotion. For each selected project, a work fee of NT\$ 80,000 is offered.

3. Technical Specifications:

(1) Spatial Structure

The interior of the experimental architectural structure is one smooth curved surface, equipped with 10K-resolution dome projection, Ambisonics sound system and audio equipment.

Dimension: The spheric screen has a diameter of 15 meters, and the height of the dome-shaped space is 7.5 meters.

Capacity: 60 to 80 persons (seated);
90 to 120 persons (standing).

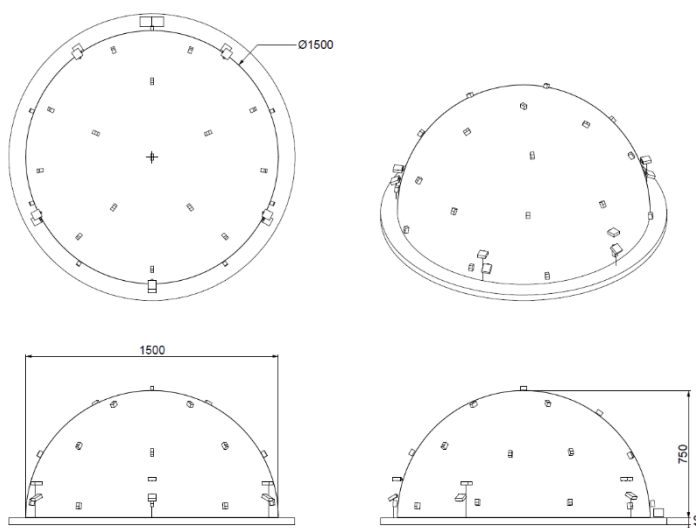

Unit CM
Scale: 1:200
Date: 2024/03/04

(2) Video Specification:

The DOME is equipped with ten sets of 10,000 lumen laser projectors, bringing the total resolution to 10K. Combined with dome-shaped blending and the technology of system interfacing, the DOME is suitable for screening video works and real-time video streaming. It is recommended to output the video with HAP or HAPQ Codec to ensure smooth playing of the video. The vids of resolution over 6144x6144 must be output with HAP chunk 16 Codec to play.

● Video Specifications

Video Format	H.265(not recommend), HAP, HAPQ
Video Resolution	4096x4096, 4960x4960, 5120x5120, 6144x6144(HAP chunk 16)
Video fps	30 or 60fps
HDR Imaging	√
Modes of Video Presentation	FishEye (FullDome); see right image below Equirectangular (2:1); see left image below

Equirectangular 2 : 1



FishEye(FullDome)

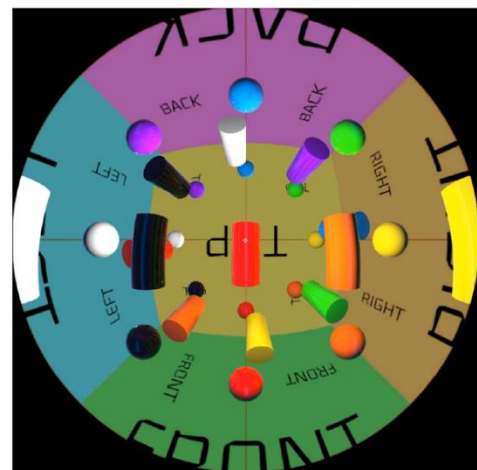

(3) Sound System

A total of 25 sets of passive speakers and 4 sets of subwoofer speakers (as shown in the figure below) are configured for surround sound on site, supporting a variety of spatial audio formats, including 4th-order Ambisonics, VBAP (vector-based amplitude panning), VBIP (Vector Base Intensity), WFS (wave field synthesis) and other multi-channel surround formats.

There is a digital console on site, and one can use the main control computer to operate and play the pre-recorded audio or use it in series with the creator’s equipment through the Dante network system. The sound sources can be input and converted through multiple channels, but it is recommended to use the Ambisonics related sound system for creation. After being selected, relevant technology introduction workshops can be arranged. It is recommended to provide audio files in WAV (Waveform Audio File Format) format to output multi-channel or Ambisonics format.

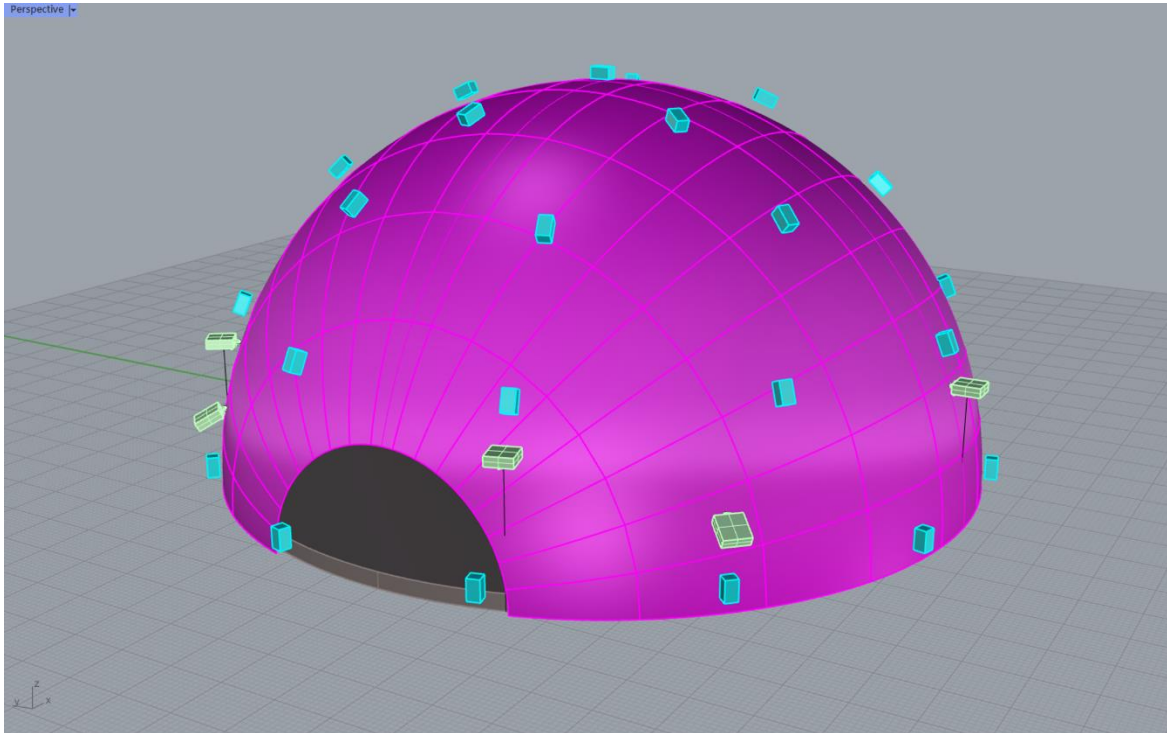

III. Applicant Eligibility

1. The open call is open to individuals (joint creation allowed) without limitation of age and nationality, and to registered groups, studios, companies, or legal persons as well.
2. Submissions cannot be projects organized or commissioned by governments, political parties, schools, or other organizations with abovementioned entities as primary shareholders or benefactors. However, projects co-organized with public art organizations are permitted.
3. Every individual or group applicant can submit maximum 2 projects (including joint creation).

IV. Selection Criteria

1. Submissions must be presented at C-LAB within the duration from November to December 2024. The submitted work is required to feature future-vision-related themes, elements or contents. Topics of submitted projects can be in these categories:
 - (1) Film/video creation: This includes but not limited to audio-visual art, experimental images, experimental animation, AR, VR, AI, algorithmic presentations, location shootings, short films, etc.
 - (2) Experimental exhibition/performance: We encourage works which use technological instruments, to surpass existing exhibition/performance frameworks, and combine technology media to connect with the site and/or locals.
 - (3) Real-time performance: Live real-time performance is encouraged, which includes but not limited to real-time algorithmic audio-visual creation, art action, performing arts work, performance art, etc.
 - (4) Short-term exhibition: Content of the exhibition shall be showcased for 3 to 7 days onsite. It is recommended to draw inspiration from the space to propose continuous live performances, interactive exhibitions and so on.

V. Resources and Requirements for Selected Applicants

1. Each selected project will receive a work fee of NT\$ 80,000 (including tax and 2nd Generation National Health Insurance; for a foreign person/organization, the tax is 20% of total amount will be withheld in accordance with regulations). In addition to the work fee mentioned above, C-LAB will not pay any other expense in any reason.
2. Selected applicants should follow C-LAB's regulations and rules to present the exhibition/performance at the designated space, with related equipment provided by the organizer.
3. Selected applicants should follow the marketing schedule of the organizer to provide materials for promotion (e.g., artwork images, traditional Mandarin and English project description, etc.)
4. Selected applicants shall only self-market after the Organizer has announced the selection line-up, and shall follow the marketing guidelines.

VI. Application

1. The open call only accepts online application. No mails are accepted.
Applicants should go to the application system at <https://open-call.clab.org.tw/> in the open call announcement published in the section of “News” on C-LAB's official website at <https://clab.org.tw/news/notice/>. Online application must be completed before **23:59:59 (Taipei Time) on 15th April, 2024 (Mon.)**. Please check all application information thoroughly. Unsuccessful application caused by incomplete information will not be notified.
2. The selection review will be in two stages: the preliminary review and interview. The interview will be conducted from April 29 (Mon.) to May 3 (Fri.) 2024. The specific time and form for interviews will be announced shortly.
3. The result of the selection will be announced on C-LAB's official website and the Facebook fan page of the Technology Media Platform no later than Friday, May 10, 2024. Selected applicants will be notified by e-mail. Non-selected applicants will not be notified.
4. The open-call information session will be hold at 11:00 – 12:00 (Taipei Time) on March 29, 2024 (Fri.) online and will be conducted primarily in Chinese. For further information about this information session, please check on “C-LAB's official website” and “C-LAB Technology Media Platform” Facebook page at <https://reurl.cc/7jZONb>.
5. Technical meeting: The meeting will be conducted at 14:00 – 16:00 on Thursday, May 16, 2024. Please make sure to reserve time for this meeting shall your work is selected
6. For any questions, please contact us via email at RDPD@clab.org.tw.

VII. Review Process and Evaluation Standard

1. The organizer will select and appoint experts, scholars, and organizer's representatives to form a review committee for evaluating the submissions.
2. The review committee will evaluate the submitted project proposals and audiovisual materials, and select projects based on the criteria mentioned in article IV, along with viability, experimentality and innovativeness. If other related references are needed from applicants, the organizer will issue a notice for more explanation and supplementary documents in advance.

VIII. Contract Signing

1. The organizer and selected applicants shall negotiate the number of rehearsals and public

performance sessions, resources, and the use of equipment. A contract will be signed after both parties reach an agreement.

2. Selected applicants must agree to the rules and regulations regarding the use of the organizer's venue, and finalize the signing of the contract before the designated date.
3. If the signing of the contract is delayed on account of the selected applicant's personal reasons, or both parties fail to reach an agreement for signing the contract, the organizer reserves the right of final approval or the right to revoke the qualification of the applicants.
4. Selected applicants should realize the projects according to the submitted project content. In the case of needing to modify the main contents of the projects, the organizer's written consent must be obtained.
5. In the cases of failing to sign the contract, projects being realized without following the contract, or the realized results not conforming to the regulations stated in the contract, the organizer has the right to revoke the qualification of the applicants, and demand partial or full return of the subsidy, depending on the severity of the case.
6. If the form of the exhibition/performance is adjusted or the exhibition/performance must be canceled due to the development of the pandemic, the organizer reserves the right to modify the implementation of the project.

IX. Remittances and Audits

1. The subsidy will be paid in full amount within a month after the first presentation of the project.
2. All affairs related to remittances, audits, and the obligations and rights of both parties will be carried out according to the contract.
3. Necessary income tax withholding will be carried out according to taxation regulations and laws.

X. Others

1. Based on the goal of promoting experimental creation to society, all exhibitions/performances are free of charge for the public.
2. If a selected project infringes the right of a third party, the selected applicant of said project shall take full legal responsibilities. If the infringement causes any damage to the right of the organizer, the selected applicant is responsible for compensation. If plagiarism and/or violation of the copyright law or other laws and regulations is involved, the organizer has the right to revoke or terminate the subsidization, and the selected applicant must return any payment made prior to the revocation or termination.
3. Selected applicants own the intellectual property right to the selected projects. The organizer is allowed to use information and material of the selected projects for non-profit purposes, including providing the unique exhibition/performance site and available technical support, conducting marketing campaign, and nurturing emerging artists or art groups.

XI. For matters not covered in this guideline, the organizer reserves the right to make necessary amendments and changes.